

## FlexiNET: Flexible Gateways Architecture for enhanced access network services and applications

Dr. Robert Haas, IBM Research, Zurich Research Lab

[rha@zurich.ibm.com](mailto:rha@zurich.ibm.com)

Next Generation Networks and Services 2005

Fribourg, Switzerland

October 31, 2005

- ✓ STREP @ “Broadband for all”  
(Specific Targeted Research Projects)
- ✓ Started March 01, 2004, duration 2 years
- ✓ [www.ist-flexinet.org](http://www.ist-flexinet.org)
- ✓ 8 partners



- ✓ **Main objective:** to accelerate the introduction of next-generation marketable services, and increase competitiveness in the telecom field by facilitating the broadening of current business models for services provisioning and exploitation.
  - ✓ Get data out of the Network elements (Data Interface and SAN)
  - ✓ Use a service-centric architecture for new applications (Applications Interface)
  - ✓ Move services and switching management towards the network edges (GW)
  - ✓ Add service programmability

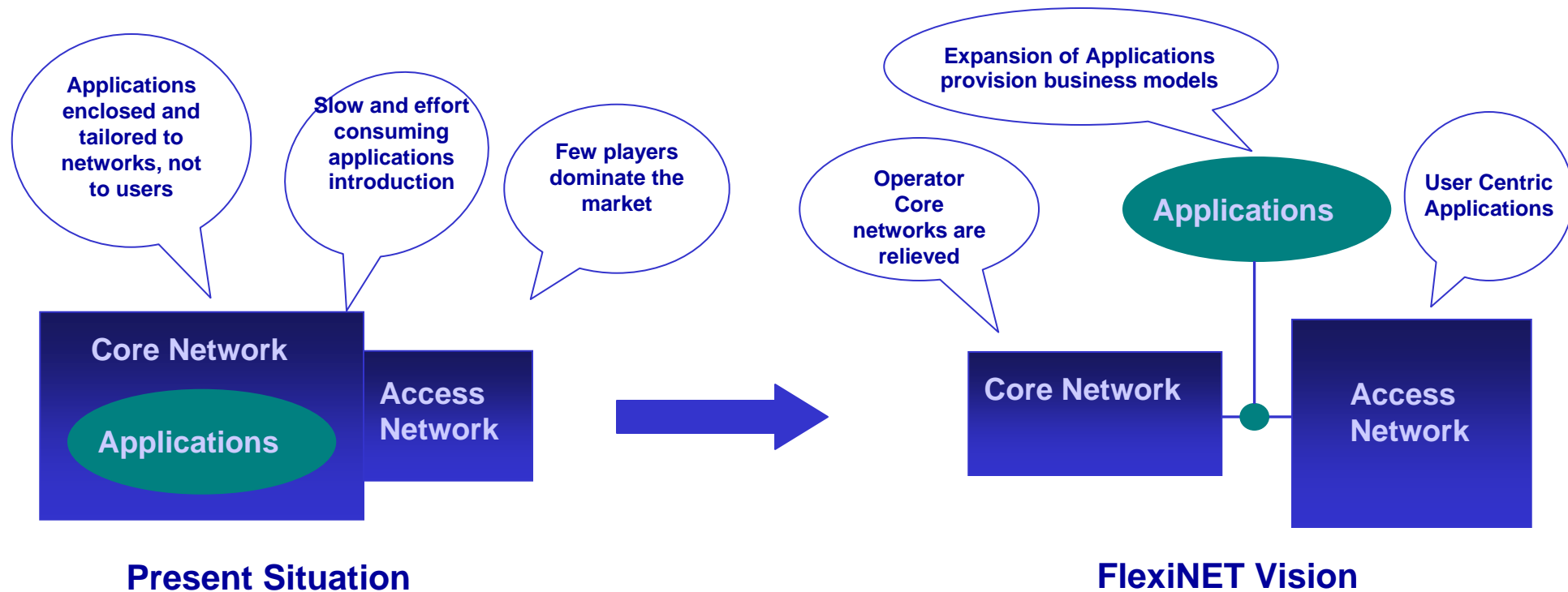

**The basic motivation for this project is to accelerate the introduction of next-generation marketable services, and increase competitiveness in the telecoms field by facilitating the broadening of current business models for services provisioning and exploitation.**

## Existing Telecom Networks Situation

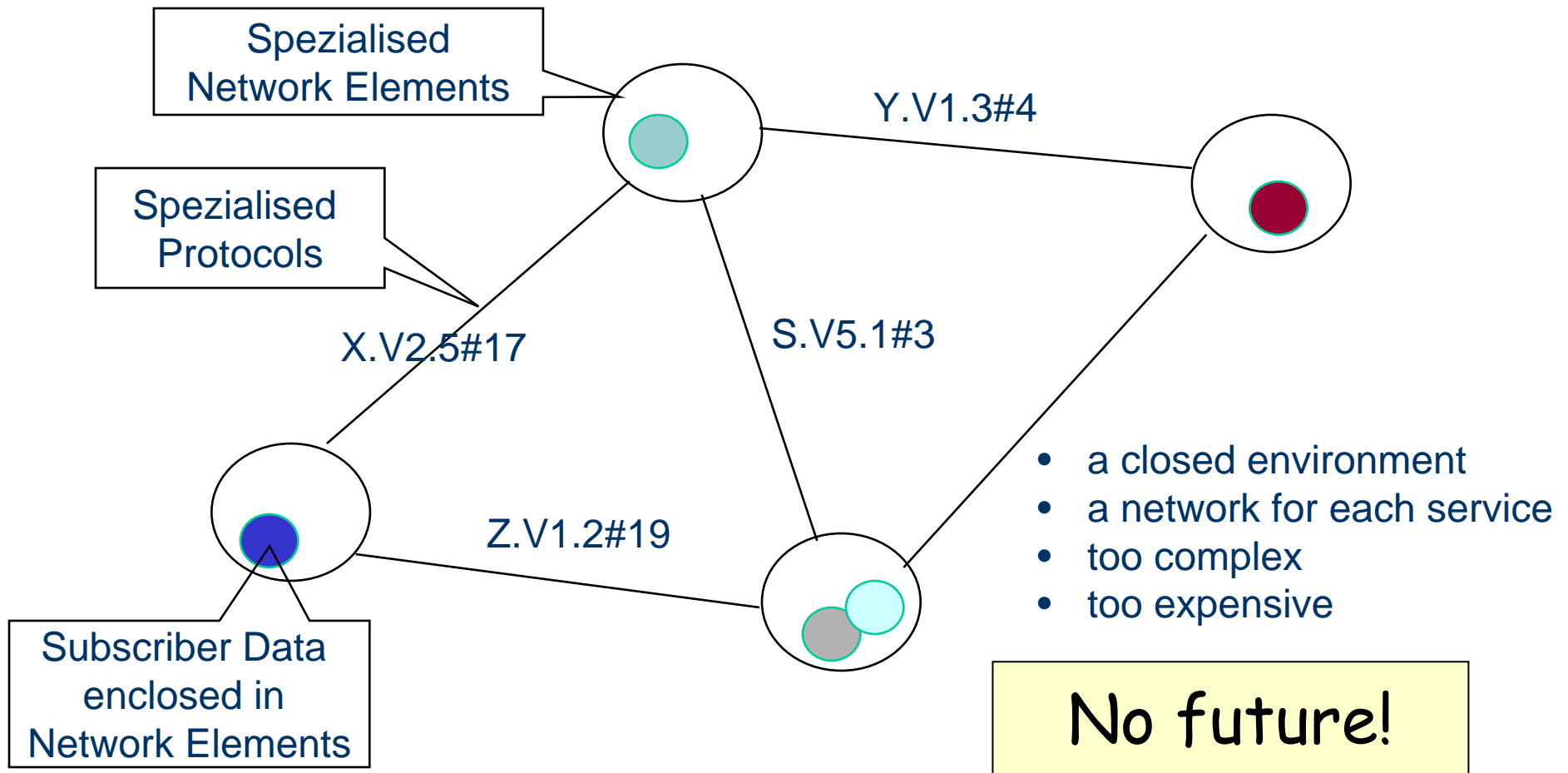

## Step 1: Get the Data out of the Network Elements

- facilitates integration
- facilitates introduction of new services
- uses standard IT technologies

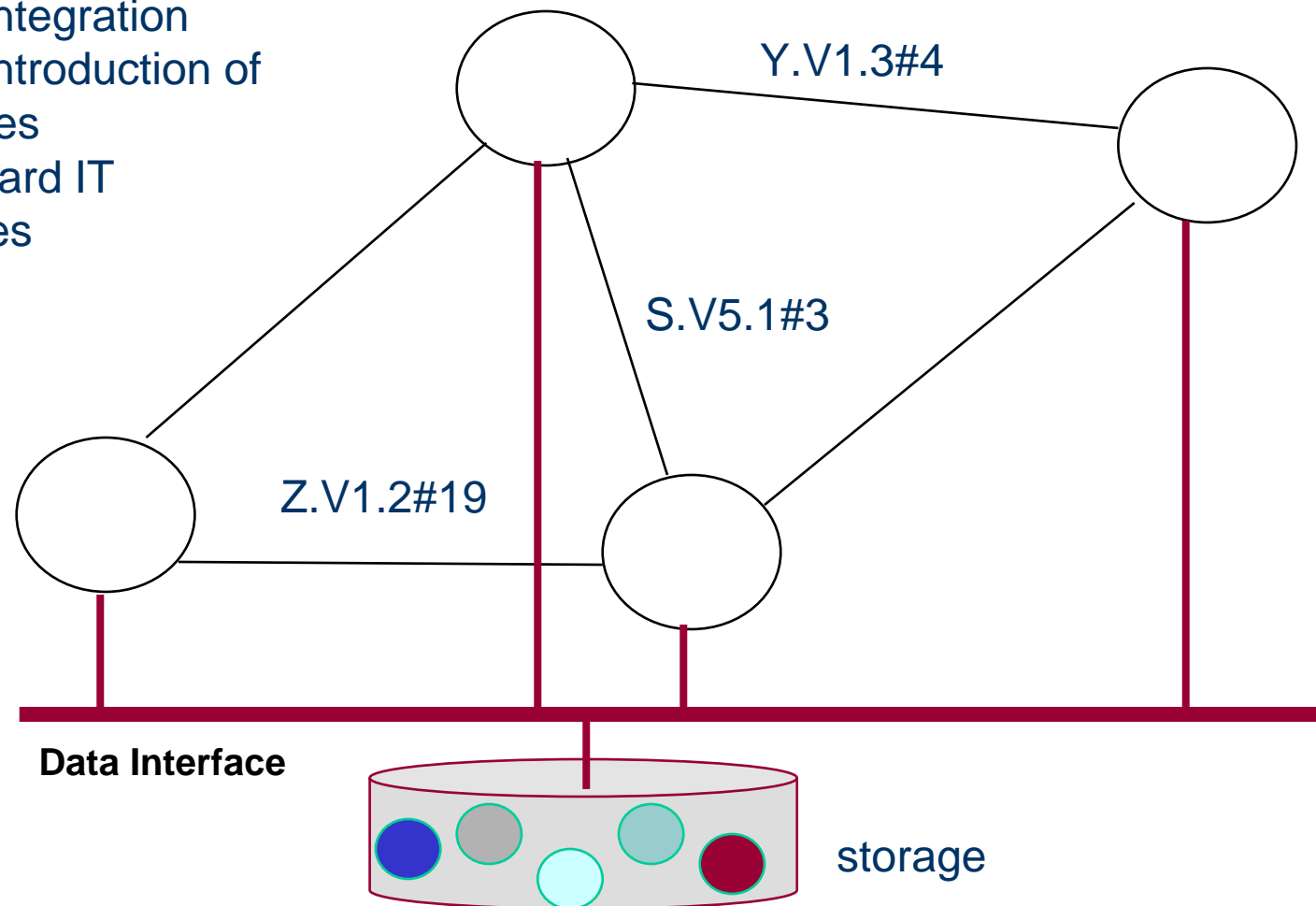

## Step 2: Use a Service-Centric Architecture for new Applications

### Application Interface

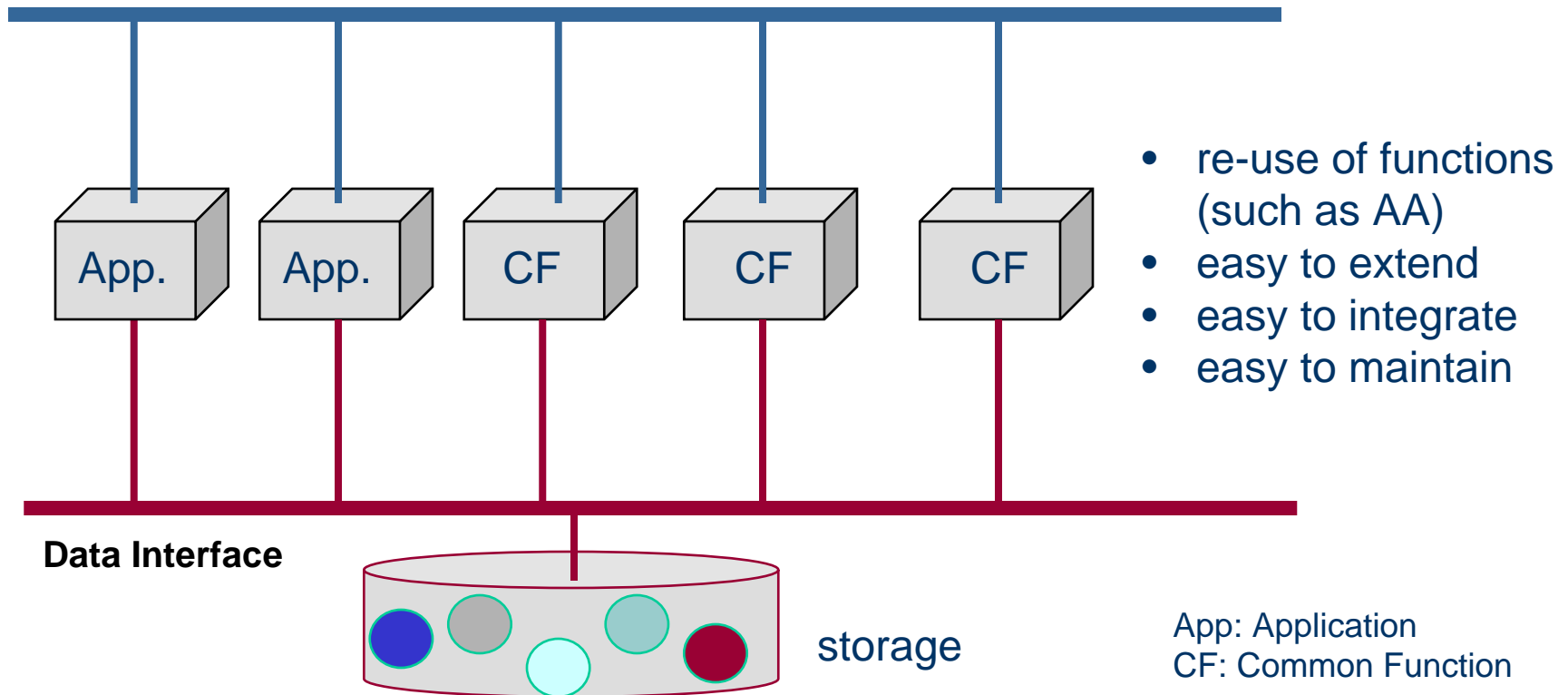

## Step 3: Integrate Legacy Infrastructure

- Utilise infrastructure investments
- Preserve existing services revenues

### Application Interface

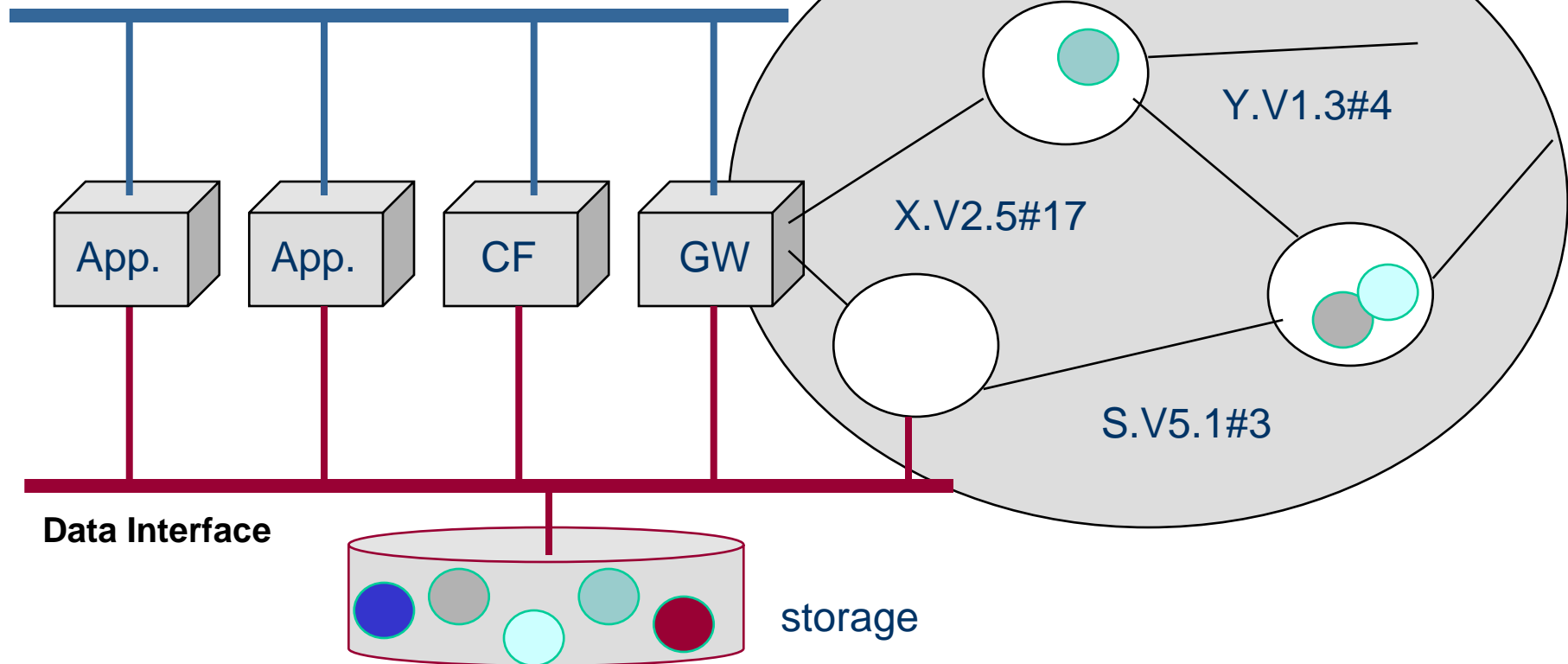

## Step 4: Move Switching, and Services Management towards the Networks Edges

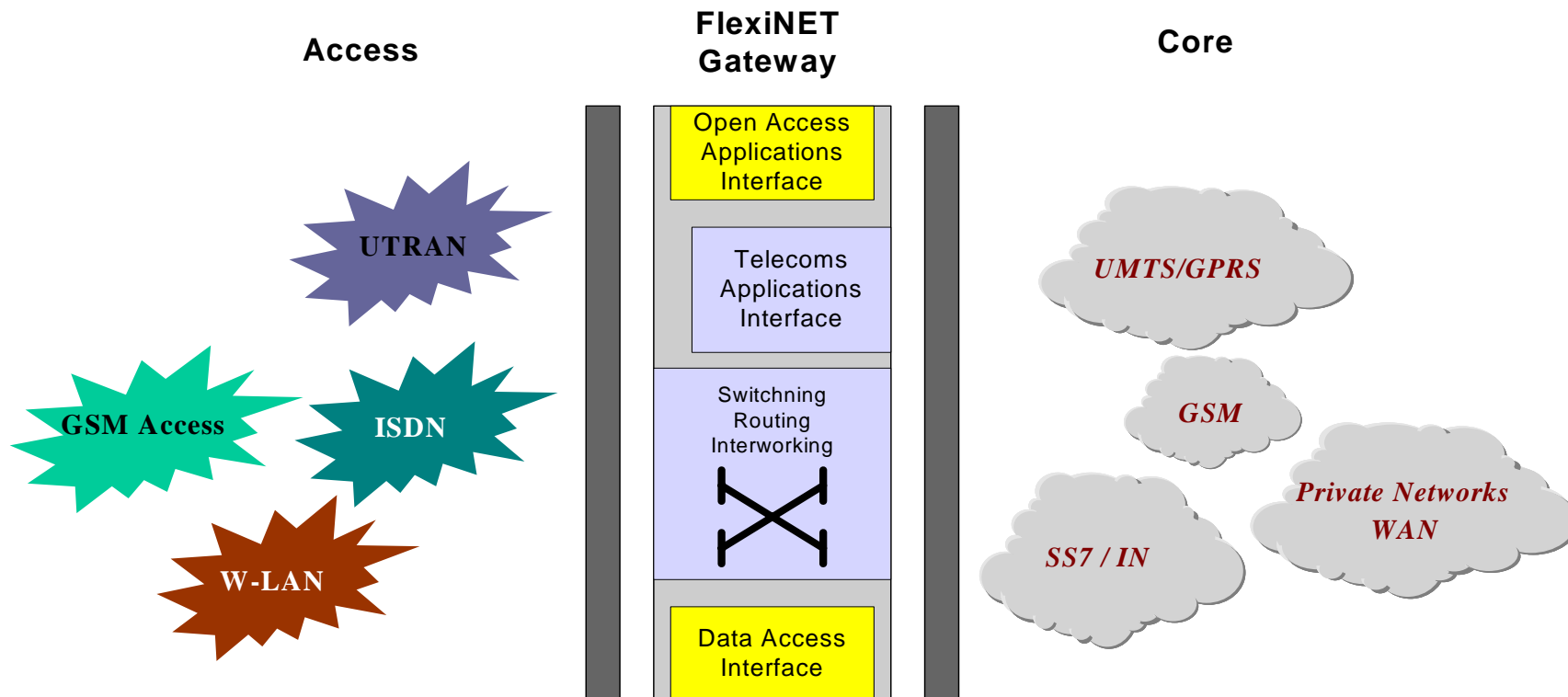

## Step 5: Introduce dynamic service deployment principles

Application Interface

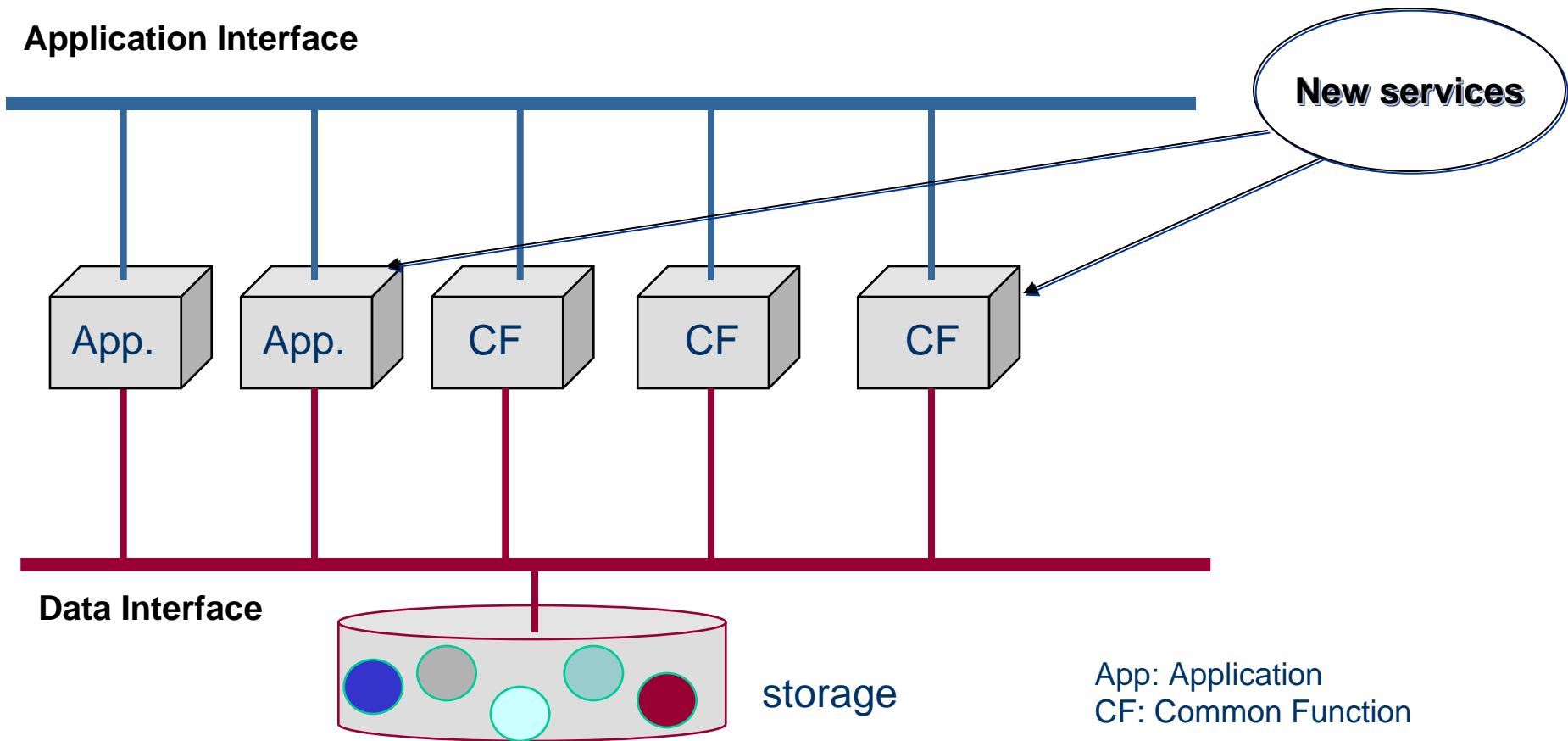

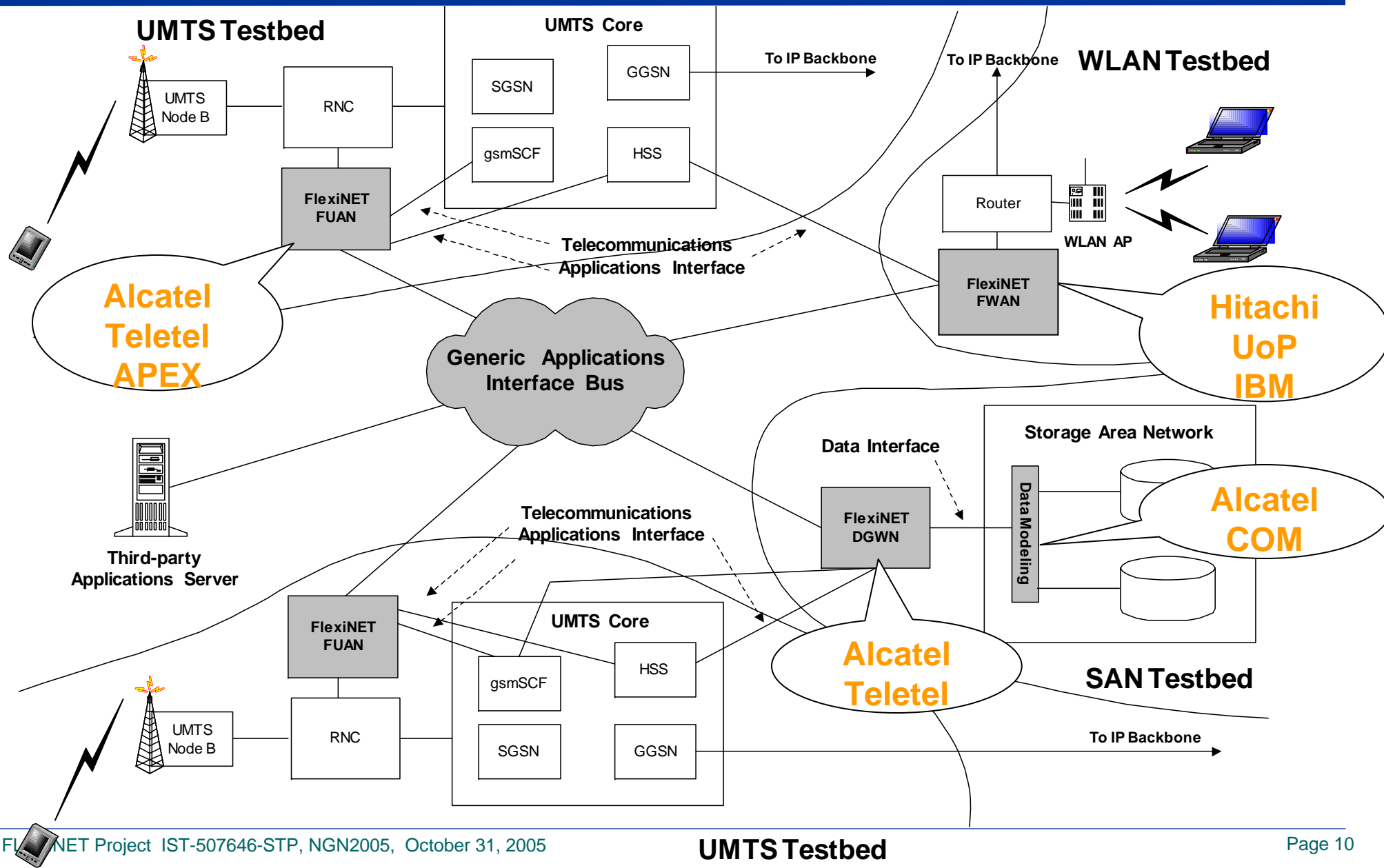



# FlexiNET: FWAN

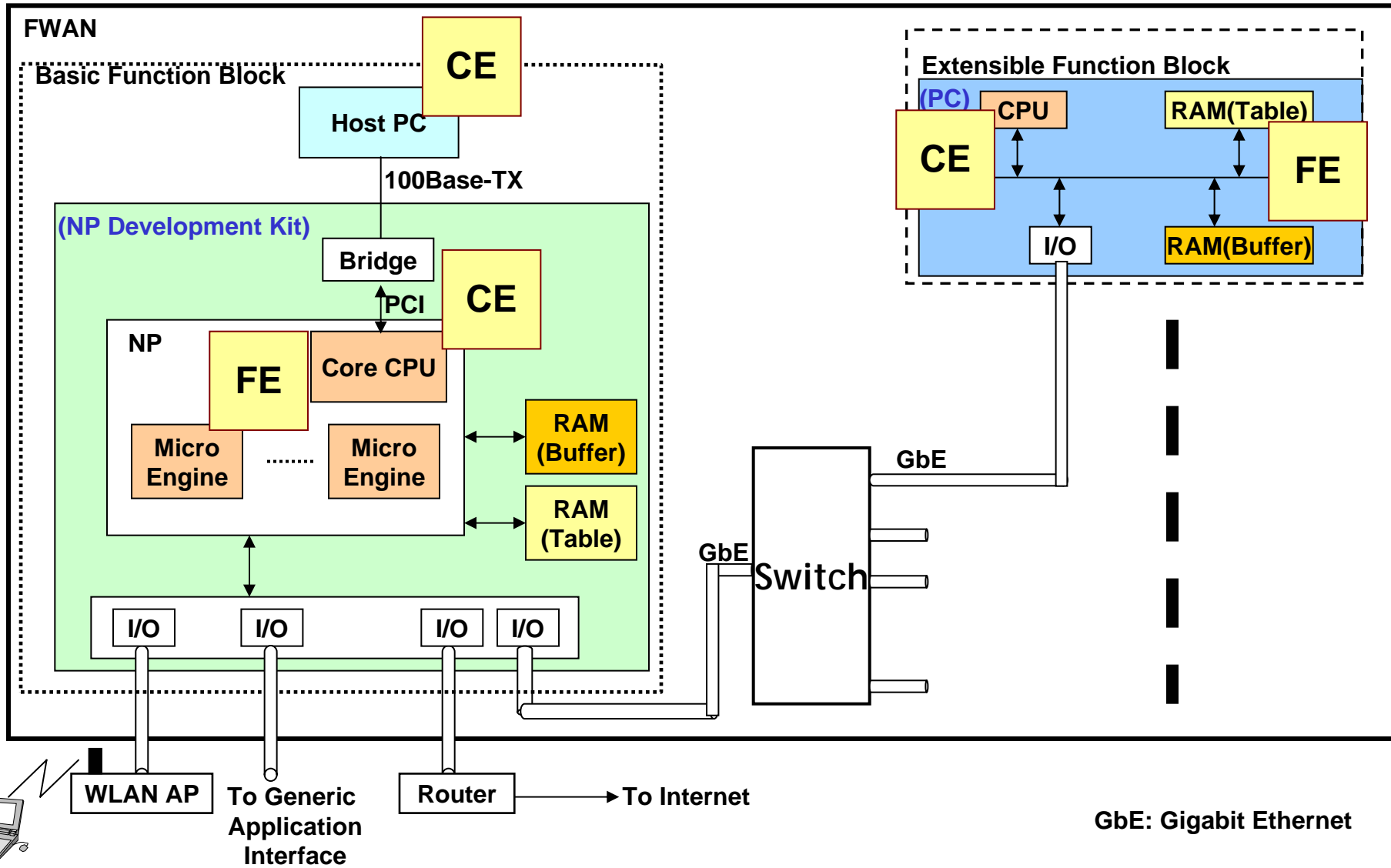

The results of FlexiNET are the following:

A value-added complementary network architecture offering cross-connect switching/ routing and advanced services and data management functions at the network access points

Evaluation of FlexiNET concept on UMTS and WLAN infrastructures

## **Expected Impact**

***Relieve core networks from data handling and signaling overhead***

***Accelerate the introduction of new services,***

***Broaden the current business models for service provisioning***